

**EQUATIONS AND TRANSFER FUNCTIONS OF MAIN ELEMENTS OF A  
MULTI-MOTORIZED AUTOMATED ELECTRIC DRIVE OF PUMPING UNIT****M.M.Khamudkhanov<sup>1</sup>, Sh.B.Umarov<sup>2</sup>**

<sup>1,2</sup>100095, Tashkent, Uzbekistan Tashkent State Technical University,  
Department of Energetic 2, Universitetskaya st.  
Phone: +998 935642170

**Abstract:** In this very article the principle of building an energy-sufficient multi-engine automated drive of water-lifting pumping unit is suggested, its main electromechanical ratios are given and equations are obtained that define the dynamics of the system and main elements were put into transfer functions.

**Key words:** a multi-engine electric drive with electrical connection by rotary chain, inverter, led by network, a pumping unit, a pumping aggregate, a driven electric engine, engine speed, a system of a machine water-lifting.

In pumping unit (PU) a system of a machine water-lifting (MWL) in order to ensure the sufficient water flow following options of building of ACS closed system are suggested: by driven electric motors engine speed, by flow of every pumping aggregates (PA) as a part of PU, by PU's total flow, by the lower pond's level and by combinations of the listed above.

The most prime and convenient on the implementation is self-contained ACS based on a rotation frequency. However, its application was complicated because of ambiguity of interrelation between efficiency of PA and of their rotation frequency that was expressed in lack of concrete analytical dependence of a form:

$$Q = f(n, H_{CT}, N, H).$$

The mathematical descriptions of electromechanical ratios of the multi-engine electric drive offered by us with electrical connection on a rotary chain (MEEC) in the mode of the coordinated rotation of the drives of the PU [1] allow not only to establish the specified dependence, but also to define under the given

operating conditions the best value of a rotation frequency of PA, thus providing resource-saving mode of PU MWL.

In our opinion, it is expedient to construct ACS based on rotation frequency of the electrical drives of PU MWL in the form of the digital electric drive (DED) implemented as a system of subordinate of management (SSM). The principle of the SSM is that the internal contour of management (for example, velocity) is subordinated to an external contour of management of some coordinate (for example, current). And in one system there can be several coordinated contours. Advantages of a creation of the system by the principle of the SSM concerning the opportunities of formation the demanded static and dynamic modes, restriction of coordinates, simplicity of adjustment are well-known, and a row of systems of the electric drives realized on the SSM, and their duties are rather widely considered in references.

In our case it makes sense to use autonomous DED in which the digital computer (DC) is only a source to entrance information, and digital correction is carried out by the express device working independently (autonomous) in relation to DC. It is known that in nonautonomous DED at the entrance the pilot signal represents an error of a mismatch that is developed by DC which at the same time performs functions of a driver unit, works as an element of comparison and as the digital correcting device.

However, the choice of the autonomous DED by us as the adjustable PU MWL electric drive is

made for a number of reasons. Firstly, dynamics of functioning of nonautonomous DEDs are immediately defined by the frequency of an output information from DC, while autonomous DEDs are in a sense invariant to this frequency. Secondly, in nonautonomous DEDs it is more difficult to exercise control of parameters in the course of their management and control, that's why the system of the electric drive of the PU MWL is possible to check only in a complex with DC. Besides, one of the main reasons is that under the terms of technological process of water flow by the pump station (PS) of MWL the water flow provided with it changes discretely depending on number of working PA which at the stages of PU assuming the poagregatny regulation of its delivery can remain for quite long time, even for the duration of the whole shift. Then the personnel of the pump station on duty just have to enter from the keyboard into the DC the data on values of the stated functioning mode of PA according to the schedule of water giving and the energy-saving regime card [2] of working of PS of MWL or on performing the current change of quantity functioning PA and according to indications of devices. After this DC counts the value of an optimum rotation frequency on the developed software and gives it in the form of a task signal.

The " MEEC — pumps — pressure head network" system represents the non-linear object described respectively by the system of non-linear differential equations. As it is well-known [3], when studying dynamics of system in the field of small deviations of its coordinates from some equilibrium state it is possible to linearize the specified equations of elements of system and, having written down them in increments of coordinates, to receive then transfer functions.

Meaning the assumptions accepted earlier and also, considering electromagnetic processes in a chain of rectified currents, proceeding from the "smooth" components of EMF of rotor and network group of valves that is fair on condition of the restricted speed of change of a pilot signal which is, generally, carried out in loop systems, and neglecting a voltage drop on gates of rectifiers, we will write down the following equations describing transition processes in the the " MEEC — pumps — pressure head network" system:

$$M_i - M_{C.i} = J_i * \frac{\partial}{\partial t} \omega_i; \quad (1)$$

$$M_i = (I_{B.i} * E_{B.i} - \frac{3}{\pi} * I_{B.i}^2 * x_{P.i}) / \omega_i; \quad (2)$$

$$E_{B.i} * s_i * -E_{du} = I_{B.i} * R_{eq.i} + L_{eq.i} * \frac{\partial}{\partial t} I_{B.i} + I_{B\Sigma} * R_{eq.gen.} + L_{eq.gen.} * \frac{\partial}{\partial t} I_{B\Sigma}; \quad (3)$$

$$E_{du} = K_2 * E_{2T} * \cos \beta \quad (4)$$

$$H_i = A_H * i_d^2 * \left( \frac{\omega_i}{\omega_{H.i}} \right)^2 + B_H * i_d * \frac{\omega_i}{\omega_{H.i}} * Q_i + C_H * Q_i^2 - R_{vi} * Q_i^2 - K_{gH.i} * \frac{\partial}{\partial t} Q_i; \quad (5)$$

$$H_i = H_{TP} + (R_{K.i} + R_{P.i}) * Q_i^2 + (K_{gK.i} + K_{gP.i}) * \frac{\partial}{\partial t} Q_i; \quad (6)$$

$$H_{TP} = H_{CT} + R_{gen.} * Q_\Sigma^2 + K_{g.TP} * \frac{\partial}{\partial t} Q_\Sigma, \quad (7)$$

where  $L_{eq.i} = 2 * x_{P.i} / \omega_i$ ,  $L_{eq.gen.} = 2 * x_T / \omega_i + L_{dr}$ ,  
 $K_{gH.i} = L_{H.i} / (g * F_{H.i})$ ,  $K_{gK.i} = L_{K.i} / (g * F_{K.i})$ ,  
 $K_{gP.i} = L_{P.i} / (g * F_{P.i})$ ,  $K_{g.TP} = L_{TP} / (g * F_{TP})$ ,  
 $I_{B\Sigma} = \sum_{i=1}^N I_{B.i}$ ,  $Q_\Sigma = \sum_{i=1}^N Q_i$ .

Here  $J_i$  – the moment of inertia of i-th PA;  $L_{eq.i}, L_{eq.gen.}$  – the equivalent inductances of a rotor chain of i-th asynchronous motor (AM) and common chain of rotor contours of the MEEC system;  $H_i, Q_i$  – the current values of a pressure and expense (giving) of i-th PA;  $\omega_{i.i}$  – a nominal angular velocity of rotation of i-th PA;  $K_{gH.i}$  – geometrical coefficient of i-th impeller pump;  $L_{H.i}$  – length of i-th impeller pump;  $F_{H.i}$  – a sectional area of a pressure head path of i-th impeller pump;  $K_{gK.i}$  – geometrical coefficient of communication pressure head the pipeline i-th PA;  $L_{\hat{E}.i}$  – length of a communication pressure piping of i-th PA;  $F_{\hat{E}.i}$  – sectional area of communication pressure head the pipeline i-th PA;  $K_{gP.i}$  – geometrical coefficient of

the bringing pressure head the pipeline i-th PA;  $L_{Di}$  – length of the bringing pressure piping of i-th PA;  $F_{Di}$  – a sectional area of the bringing pressure head the pipeline i-th PA;  $H_{\partial D}$  – the developed pressure in the place of join of the bringing pressure head pipelines in the common pressure head water duct of PU;  $K_{g.TP}$  – geometrical coefficient of the com-mon pressure piping (water duct) of PU;  $L_{\partial D}$  – extent of the common pressure piping of PU;  $F_{\partial D}$  – sectional area of the common pressure piping of PU.

In view of the fact that PAs of pump stations of MWL are, in common, completed with the same pumps and electric motors [4], i.e. they have absolutely identical hydropower inventory, the index  $i$  can be lowered in expressions and also it is plausible to consider, that  $I_{B\Sigma} = I_B * N$  и  $Q_{\Sigma} = Q * N$ .

In this case an equation of motion of the PA's (1) electric drive in small deviations from the chosen working point, considering  $M_C = const$ , will register in a form:

$$\Delta M = J * \frac{\partial}{\partial t} \Delta \omega. \quad (8)$$

In a functional form the equation (8) can be presented as:

$$\Delta \omega(\delta) = \Delta M(p) / Jp. \quad (9)$$

Then the transfer function of this dynamic link can be written down as follows:

$$W_d(p) = \Delta \omega(p) / \Delta M(p) = 1 / Jp. \quad (10)$$

The equation of a turning couple of the drive induction of PA  $M = f(I_B)$  electric engine according to (2) in increments will take a form:

$$\Delta M = (E_B - 6 * x_p * I_{B0} / \pi) * \Delta I_B / \omega \quad (11)$$

or in a functional look

$$\Delta M(p) = (E_B - 6 * x_p * I_{B0} / \pi) * \Delta I(p) / \omega. \quad (12)$$

Here  $I_{B0}$  – the rectified rotor current corresponding to the position of the working point (equilibrium state of the system).

From (12) we will define a transfer function of a dynamic element of electromechanical transformation:

$$W_{el.M}(p) = \Delta M(p) / \Delta I_B(p) = K_{M0} = (E_B - 6 * x_p * I_{B0} / \pi) / \omega. \quad (13)$$

From expression (13) it is visible that  $K_{M0}$  changes with change of the regime working point of PA which determines size of  $I_{B0}$ .

The EMF equilibrium equation for a contour of a chain of a rectified current of a AM (3) in increments is represented as:

$$\Delta E_B * s - \Delta E_{du} = (R_{eq} + N * R_{eq.gen}) * \Delta I_B + (L_{eq} * N * L_{eq.gen}) * \frac{\partial}{\partial t} \Delta I_B. \quad (14)$$

From here the transfer function of a dynamic chain element of a rectified current of the AM will be written as follows:

$$W_{BT}(p) = 1 / [(R_{eq} + N * R_{eq.gen}) * (T_{eq} * p + 1)] = 1 / [R'_{eq} * (T_{eq} * p + 1)], \quad (15)$$

where  $T_{eq} = \frac{(L_{eq} + N * L_{eq.gen})}{(R_{eq} + N * R_{eq.gen})}$  – a time constant of a chain of a rectified current;

$R'_{eq} = R_{eq} + N * R_{eq.gen}$  – the equivalent resistance of rotor AM contour.

In order to receive a transfer function of the detector bridge of the rotor chain of the AM we will write down:

$$E_{dp} = E_B * s = 1,35 * E_p * (1 - \Delta \omega / \omega), \quad (16)$$

where  $E_{dp}$  – the rectified EMF of a rotor chain of a AM.

From here

$$E_{dp}(p) = -1,35 * E_p * \Delta \omega(p) / \omega. \quad (17)$$

Then the required transfer function will be defined as:

$$W_B(p) = -1,35 * E_p / \omega. \quad (18)$$

In order to receive a transfer function of the inverter conducted by network (ICN) with the control unit, it is necessary to consider that its dynamic properties are defined as a discretization of work of ICN consisting in transformation of the continuous function of the entrance pilot signal to discrete function of instants of an unclosing of thyristors, as well as filters, typically, that join at the entrance of the pulse and phase device in order

to increase its noise immunity. It is accepted to represent a transfer function of ICN with the control unit as an aperiodic element of the first order from the time constant  $T_{ICN}$  equal of 4-10 ms and a transmission factor  $K_{ICN}$ . As dynamic indexes of ICN with the filter on an entrance of the ICN control unit depends a little on type of switching and the law of management we wrote down expression (4) for the inverter with the law of the symmetric management at natural switching of current,. In the vertical principle of management of ICN and a sawtooth reference voltage of pulse and phase management system the corner  $\beta$  is defined by an entrance signal of management  $U_M$  as:

$$\beta = U_M * (\pi/2) / U_{M.\max} , \quad (19)$$

where  $U_{M.\max}$  – the maximal tension of management at.

Then expression (4) will take a form:

$$E_{du} = K_2 * E_{2T} * \cos[U_M * (\pi/2) / U_{M.\max} ] . \quad (20)$$

By displaying the non-linear equation (20) in Taylor series and rejecting terms of the higher order, we will receive:

$$E_{du} + \Delta E_{du} = K_2 * E_{2T} * \cos[U_{M0} * (\pi/2) / U_{M.\max} ] + \frac{\partial \{K_2 * E_{2T} * \cos[U_{M0} * (\pi/2) / U_{M.\max} ]\}}{\partial t} * \Delta U_M . \quad (21)$$

By subtracting the equation of statics (20) from a ratio (21), we will receive the equation of EMF of the inverter conducted by network with the control unit (CU) of ICN in increments:

$$\Delta E_{du} = -K_2 * E_{2T} * \sin[U_{M0} * (\pi/2) / U_{M.\max} ] * \Delta U_M * (\pi/2) / U_{M.\max} . \quad (22)$$

Then

$$K_{ICN} = K_2 * E_{2T} * \sin[U_{M0} * (\pi/2) / U_{M.\max} ] * \pi * U_{M.\max} / 2 .$$

On the basis of explained the transfer function of ICN with CU of ICN is expressed as:

$$W_{ICN}(p) = K_{ICN} / (T_{ICN} * p + 1) . \quad (23)$$

It is known that in dynamic characteristics of "the pump - pressure head network" system it is necessary to consider influence of inertia of water

on the value of an operating pressure in a pressure piping and within a flowing path of an impeller pump which is made by introduction of the padding amendment which found the reflection in the equations (5) – (7). From the equation (5) of the impeller pump with speed coefficient  $n_s < 150$ , which is received by taking into account losses in a vacuum line upon transition to the equation in increments, with implementation of its transformation, and as a result subtracting the equation of statics (5) from the received dynamical equation and also neglecting items of the second infinitesimal order, we will receive:

$$\Delta H = K_\omega * \Delta \varpi - K_f * (\dot{O}_i * \delta + 1) * \Delta Q , \quad (24)$$

where

$$K_\omega = 2 * A_H * i_d^2 * \omega_0 / \omega_H^2 + B_H * i_d * Q_0 / \omega_H ,$$

$$K_H = B_H * i_d * \omega_0 / \omega_H ,$$

$$T_H = [2 * (C_H - R_V) * Q_0 + K_{Af} ] / K_H .$$

Here  $K_\omega$  – a constant of proportionality between a pressure and speed rotations of an impeller pump;  $\omega_0$ ,  $Q_0$  – the speed of rotation and giving of an impeller pump in the worker to the regime point corresponding to an equilibrium state;  $K_H$  – a constant of proportionality between a pressure and given expense of an impeller pump;  $\dot{O}_i$  – time constant of an impeller pump.

In case of operating the impeller pump with speed  $150 < n_s < 300$ , in the equation (5) the item  $B_H * i_d * Q * \omega / \omega_H$  will transform into  $B_H * Q * \omega / \omega_H$ , and the item  $C_H * Q^2$  will be transformed into  $C_H * Q^2 / i_d^2$ .

Thus, the impeller pump can be presented in the form of two dynamic elements with transfer functions:

$$W_{H1}(p) = K_\omega , \quad (25)$$

$$W_{H2}(p) = K_H * (T_H * p + 1) \quad (26)$$

For the purpose of definition of the equation for all pressure head network system let us represent the received expressions for the communication and bringing pressure piping (6) and also the common pressure piping (water duct) of PU (7) in the following form for their joint solution:

$$H = H_{CT} + (R_K + R_P + N^2 * R_{gen}) * \Delta Q + (K_{gK} + K_{gP} + N * K_{gTP}) * \frac{\partial}{\partial t} Q. \quad (27)$$

The equation (27) in increments will be defined as:

$$\Delta H = 2 * Q_0 * (R_K + R_P + N^2 * R_{gen}) * \Delta Q + (K_{gK} + K_{gP} + N * K_{gTP}) * \frac{\partial}{\partial t} \Delta Q. \quad (28)$$

or in a functional look:

$$\Delta H(p) = K_T * (T_T * p + 1) * \Delta Q(p), \quad (29)$$

where

$K_T = 2 * Q_0 * (R_K + R_P * N^2 * R_{gen})$  – linearization coefficient;

$T_T = (K_{gK} + K_{gP} + N * K_{gTP}) / K_T$  – time constant of pressure head network.

Therefore, the transfer function of the PU pressure head network will be defined as:

$$W_{HT}(p) = \Delta Q(p) / \Delta H(p) = 1 / [K_T * (T_T * p + 1)]. \quad (30)$$

On the basis of a set of equations (1) – (7) and the received transfer functions of dynamic elements the linearized block diagram of the "MEEC – the Pump – Pressure Head Network" system submitted in fig. 1 is made.

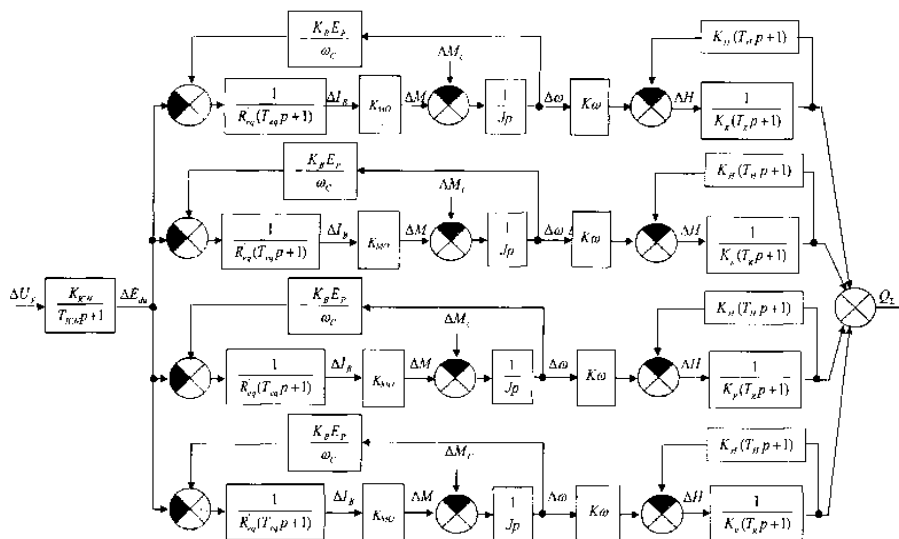

Fig. 1. Linearized block diagram of the "MEEC – the pump – pressure head network" system.

Thus, as can be seen from the provided block diagram the system has identical channels of regulation (in this case N= 4) that explains acceptance in practice of projection and operation of PS of MWL, completion of PA with identical types of electric engines and with identical parameters of their rotor contours AM and also equipping PU with the same pumps that possess the identical performance characteristics. Interference of PA systems by a chain of rectified rotor currents of drive electric motors, as well as by a pipeline contour through the connection place to the common pressure piping of PU is the characteristic feature of this system which is considered in the above-stated expressions of transfer functions and has significant effect on dynamics on whole system in general.

## REFERENCES

1. M.M. Khamudkhanov. Pumping unit multimotor electric drive with electric coupling by rotor circuit under conformal rotation mode. Ninth World Conference on Intelligent Systems for Industrial Automation, WCIS - 2016. Tashkent, Uzbekistan. – p. 186-192.
2. Khamudkhanov M.M. Formation of an energy-efficient regime map for the operation of a pumping station for water-lift systems. Journal - Problems of energy and resource saving. – Tashkent, Uzbekistan, 2012. № 1-2. – p. 136-143.
3. T.S. Kamalov, M.M. Khamudkhanov. The system of the electric drive of pumping installations of machine irrigation. Tashkent, Uzbekistan: «Fan», 1985. 96 p.
4. M.M. Khamudkhanov. Pumping station of machine water-lifting systems as an object of managing energy and resource saving. Journal – Vestnic of the Tashkent State Technical University. – Tashkent, Uzbekistan, 2013. № 2. – p. 67-73.